

PFEIFER

NEW! Now tested in vertical and parallel directions to the wall plane!

If you have transverse-force-stressed wall joints...



10/2007

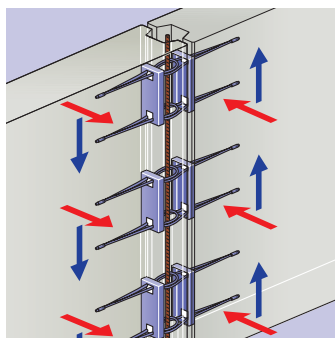

PFEIFER VS[®] Plus-Box System

**PFEIFER
SEIL- UND HEBETECHNIK
GMBH**

DR.-KARL-LENZ-STRASSE 66
87700 MEMMINGEN

TEL. Engineering
Dept. +49 (0) 83 31-937-345
Sales +49 (0) 83 31-937-312

FAX +49 (0) 83 31-937-342
E-MAIL export-bt@pfeifer.de
INTERNET www.pfeifer.de

PFEIFER VS® Plus-Box System

Tested for Transverse Forces in Parallel and Vertical Directions

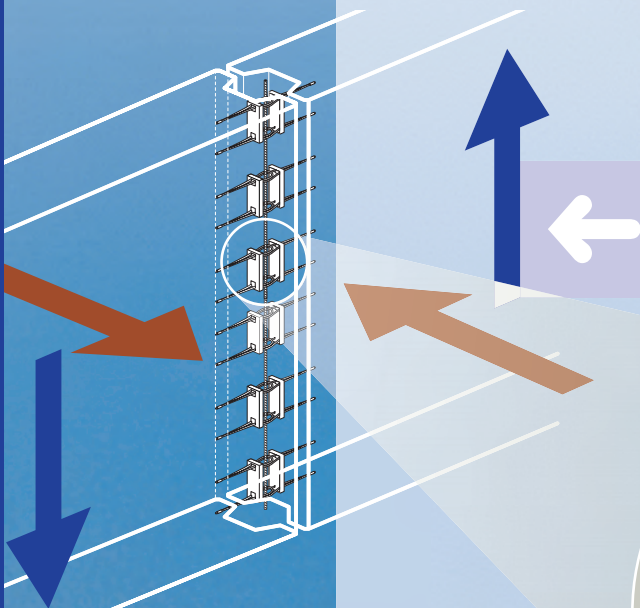

Plus Thanks to Extensive Analyses

- Broader application range: $Q_{vertical}$ and $Q_{parallel}$ tested with extensive use and interaction
- High bearing capacities thanks to improved bearing model with very friendly failure mode

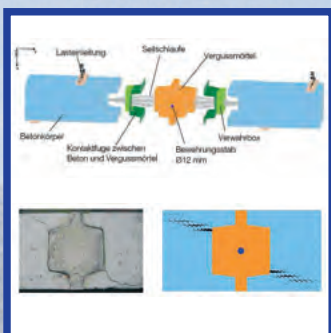
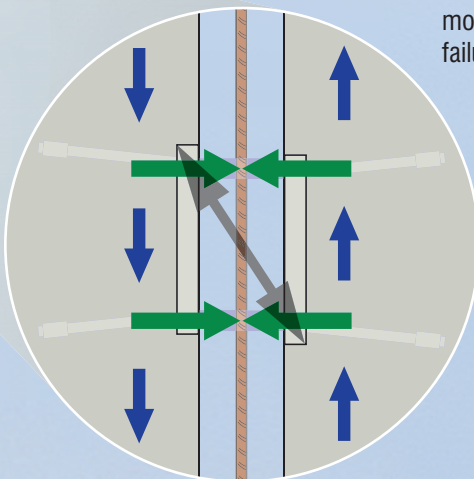

- Usability considered as limit criterion (crack width = 0.3 mm)

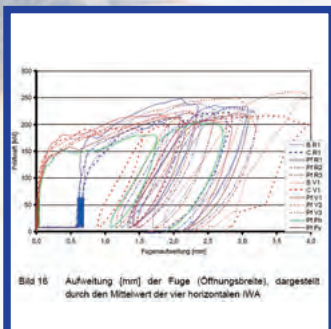

- Security checked and tested by German RWTH Aachen and Prof. Dr. Hegger



Plus with the Quality



- Constant quality thanks to automated fabrication
- Tilted-out loops fixed correctly by holding clips
- Captive identification by permanent signs stamped into sheet
- Easy stackable hardcover cartons with evident product marking
- No foaming-up of the concrete by aluminum, since steel rope clamp

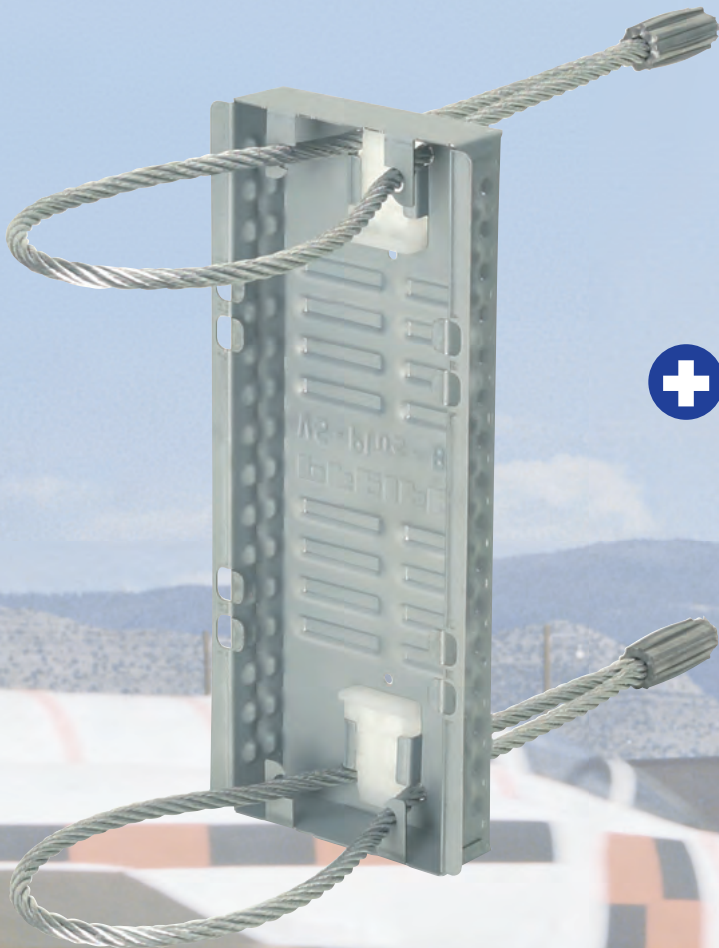

Plus for the Designer

- General German Technical Approval
- Both for outdoor construction units and for indoor construction units
- Useable in fire-protection walls
- Profi-Software for easy dimensioning as customer service free of cost

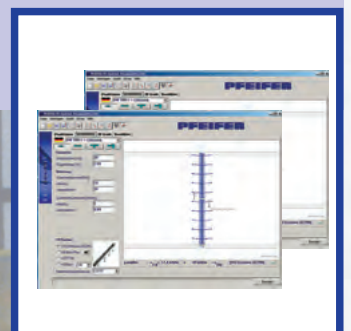

PFEIFER VS[®] Plus-Box System Tested for Transverse Forces in Parallel and Vertical Directions

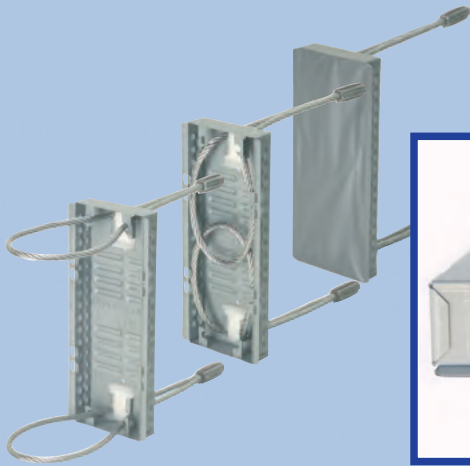

Plus with the VS[®] Plus-Box

- Correct fixation of closed and tilted-up loops
- Strongly raw bottom profiling for Q_{II}
- All-side-closed sheet box prevents penetration of concrete slurry
- Stable box with tightly-folded sheet ends on both the front faces



Plus in Case of the Precast Part Production

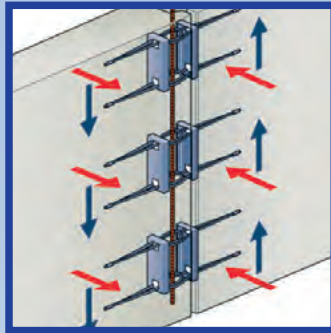

- Easy handling thanks to double loop = half the mounting time
- Lateral deep profile tooting for preventing extraction of the VS[®] Plus-Box from the concrete unit during formwork stripping
- Completely plate construction mode prevents conflicts with surface reinforcement
- Double loop elements permit adaptation to stress by variable intermediate distances



Plus in Case of the Precast Part Mounting



- Mounting with breaks is possible without any problem thanks to use of flexible rope loops
- No removal of plastic parts or of sheet parts
- Nearly no wastage, thanks to box covering by environment-friendly tape
- No formation of rust, as box and rope are galvanized



Plus when Purchasing

- Only one loop length and one box geometry, consequently low stock-keeping and advantageous job-scheduling
- Low priced VS[®] Pagel[®] grout by direct purchase from the manufacturer without distributor



PFEIFER VS® Plus-Box

Item No. 05.032



PFEIFER

Junction elements
VS® Plus-Box

The PFEIFER VS® Plus-Box serves as connection of concrete elements in case of transverse force action in vertical + parallel direction. The box consists of a construction-true and stable steel sheet box containing the tilting-out flexible rope connection loops. Wall joints can be carried out beneficially, easily and reliably.

For grouting the joint the high-resistant, very well-flowing and self-compacting VS® Pagel® grout must be foreseen.

Products:

- Box: steel sheet, galvanized
- Steel rope: high-resistant, galvanized,
- Steel rope clamp
- Cover: tape

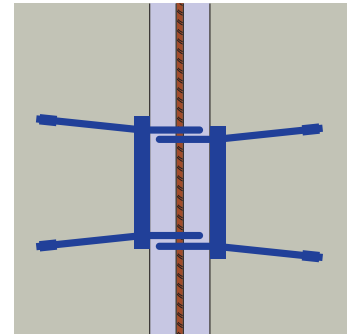
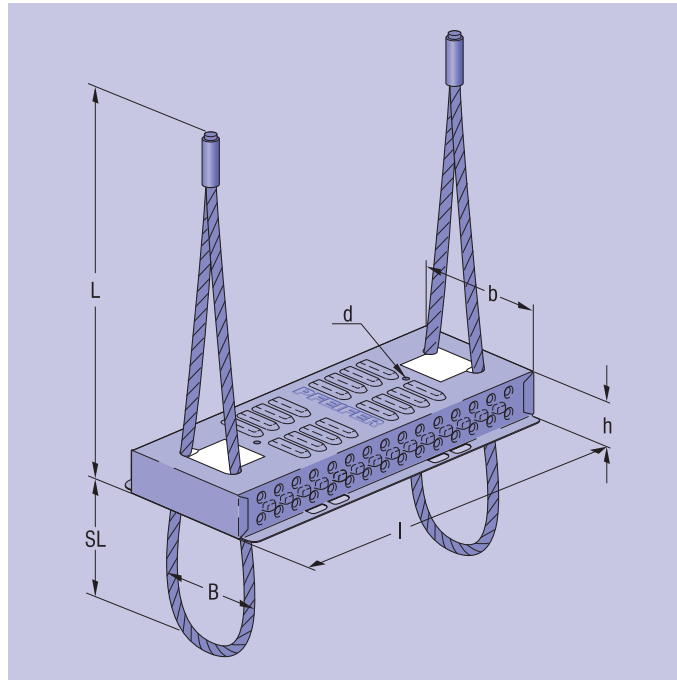

Product protected

Order No.	Type	Dimensions mm							Color clip	Packing unit/piece	Weight approx. kg/piece
		b	l	h	d	L	SL	B			
05.032.100	VS® Plus-Box	80	220	25	3	212	100	60	white □	250	0,54

Ordering example for 4000 VS® Plus-Boxes:
4000 PFEIFER VS® Plus-Boxes, order No. 05.032.100

General Installation Instructions

VS® Plus-Box System

Application Notices

The PFEIFER VS® Plus-Box system is appropriate for the connection of steel-reinforced concrete precast walls of concrete quality = C30/37 or of better quality. The components of the system are the VS® Plus-Box and the corresponding VS® Pregel® grout (fig. 1). This system is only this effective in this combination.

The VS® Plus-Box can be used in case of butt joint (fig. 2), of angle joint (fig. 3), of T-shaped joint (fig. 4) and of wall/column connections (fig. 5).

The wall connection can be stressed from wall thicknesses ≥ 140 mm for transverse force parallelly to the joint (in wall plane) for influences from mainly dead loads (fig. 7). The joint geometry must be carried out (fig. 6).



Figure 1: VS® Plus system, consisting of the VS® Plus-Box and of the corresponding VS® Pregel® grout

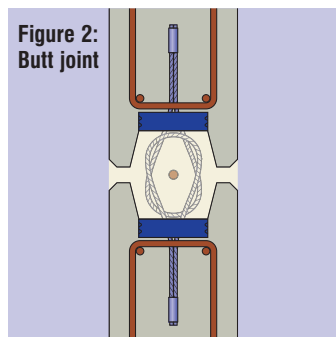

Figure 2: Butt joint

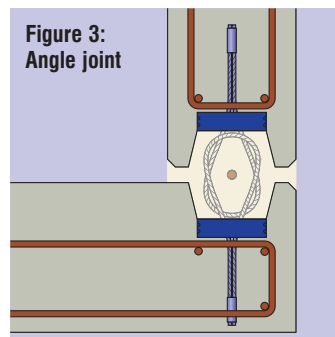

Figure 3: Angle joint

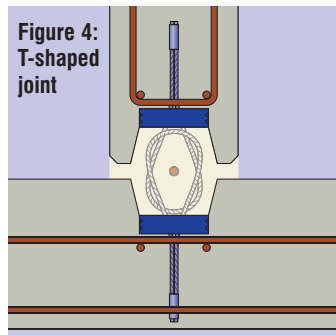

Figure 4: T-shaped joint

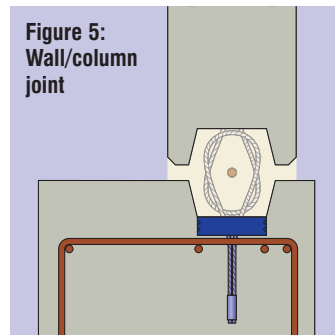

Figure 5: Wall/column joint

Transverse forces vertically to the joint (vertically to the wall plane) for wall thicknesses ≥ 180 mm are now also regulated by General German Technical Approval from mainly dead loads (fig. 8).

The overlappings of both stress directions (fig. 17) are possible according to the interaction diagram (fig. 16).

Designed pull stresses in the joint in loop direction must be excluded or must be absorbed by other appropriate static actions.

Construction units, which are exposed to constraints and variations of the normal surface temperatures up to 80 °C can develop very large forces, which cannot be supported by standard concrete precast connections. The VS® Plus-Box is not designed for this, either. As constraining forces must be avoided, the VS® Plus-Box is mainly foreseen for joining heat-insulated construction units or construction units within the indoor area without more severe constraining conditions. The designer must consider a crack width limitation of 0.3 mm. In case of a mounted outdoor insulation or of use of a sandwich panel constraints from temperature are evidently reduced in such a way that then the VS® Plus-Box system can be used. Unscheduled constraints, which are not to be excluded, can nonetheless be sustained.

Construction unit applications with direct exposure to weather action are also possible when there is proven that the joint complies with the corresponding crack width limitations, DIN 1045-1:2001-07 chart 18, (like XC4, requirement class E, steel-reinforced concrete, $w_k = 0.3$ mm) or that the corrosionprotection is guaranteed by other actions. The joint itself

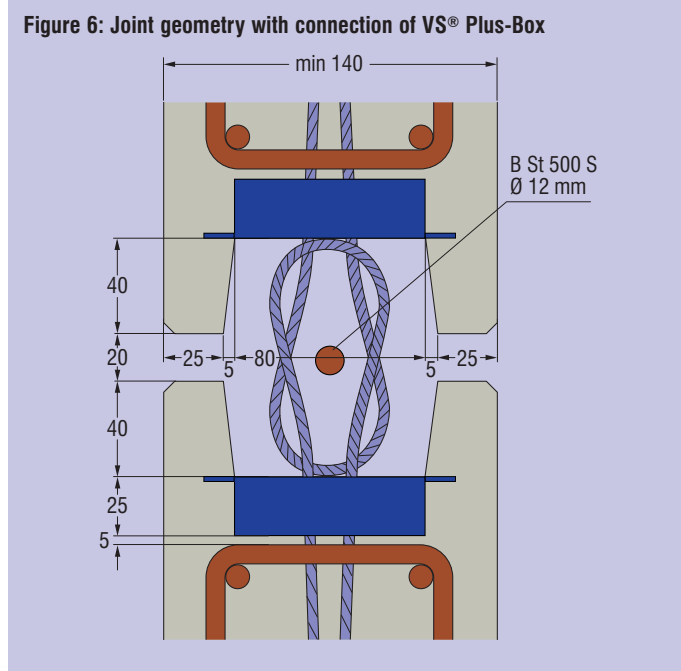

Figure 6: Joint geometry with connection of VS® Plus-Box

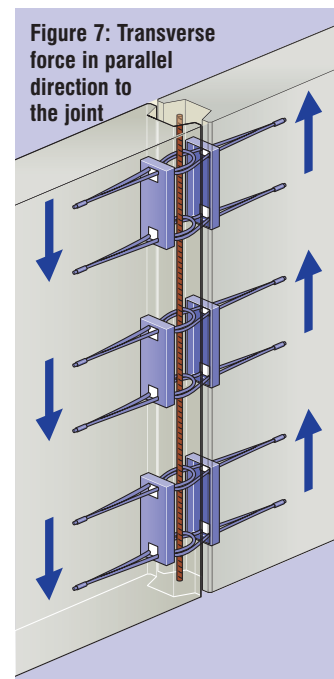

Figure 7: Transverse force in parallel direction to the joint

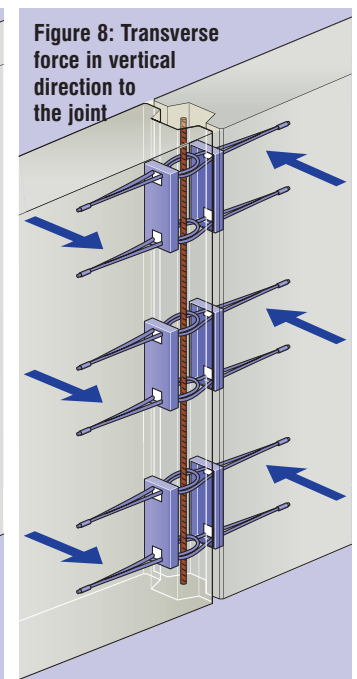

Figure 8: Transverse force in vertical direction to the joint

can open by $w_k = 0.1$ mm at transverse forces in parallel direction in case of working load. This must be taken into account additionally to all other crack-causing influences.

Reinforcement and Concrete Cover

For the VS® Plus-Box system always carry out the reinforcement's installation in the concrete precast part as follows: the reinforcement (fig. 6 and 13), the stirrup with $\varnothing = 8$ mm per loop and the vertical mounting bars with $\varnothing = 10$ mm. The rope anchoring forms with the stirrup an overlapping for transferring the forces. Surface reinforcement or further reinforcement is recommended, but must be fixed by the structure designer and is not fixed by Technical Approval in this case. The reinforcement shown in the figures are necessary for initiating the forces from the loops of the VS® Plus-Box into the construction unit. This also includes the vertical bars behind the box.

For securing the concrete flanges or in order to prevent any constructional shearing-off, the structure designers should foresee additional reinforcement actions like continuous meshes and bars in the corners of the flanges, as required by the construction units. The same normally is valid according to the wall/column connection (fig. 5) or to the wall/wall/corner connection (fig. 3). Here also, the reinforcing elements necessary for initializing the forces are shown only.

In the wall construction unit the stirrups must be mounted with spacing = 5 mm to the VS® Plus-Box (fig. 9). The vertical arrangement of the superposed stirrups can also be seen in figure 13. The stirrups can also be arranged between the loops.

The minimum construction unit thickness is 140 mm (transverse force only possible in vertical direction to the joint) (fig. 6), so that the minimum concrete cover on the steel sheet box is 30 mm. The anchoring stirrups and for the VS® long box TZ100 a minimum concrete cover = 45 mm to the sheet profile. The anchoring length of the stirrups must be fixed by the responsible designer according to the chosen concrete quality. The concrete cover of the stirrups will be fixed according to the exposition class.

Joint and Tolerance of Construction Unit

The standard geometry of the construction unit joint foresees a slot width = 20 mm between the wall units (fig. 6 and 10). With the standard joint the optimum overlapping of 80 mm is guaranteed.

The joint may shrink up to a minimum joint of 10 mm (fig. 12). The maximum width of the joint may be 40 mm (fig. 11).

The plugged-in concrete reinforcing steel of $\varnothing = 12$ mm passing through the loop overlapping after the wall mounting is important for the bearing behavior of the joint connection. The bar is statically required as transverse reinforcement (fig. 10, 11, 12 and 14).

Installation Height Tolerance

The VS® Plus-Box connection works as overlapping joint. For this, each of the loops must lie within certain tolerances in vertical + horizontal directions.

In vertical direction the loops must normally be mounted without offset, in such a way that they contact with each other and are superposed directly (fig. 14). This can be obtained with the same arrangement of the boxes from base point of the construction units to be joined.

As wrong position a maximum vertical tolerance = 20 mm is permissible if the loops are joined together after offsetting of the wall elements, e.g. by means of fixing wire through the joint or by similar actions (fig. 15).

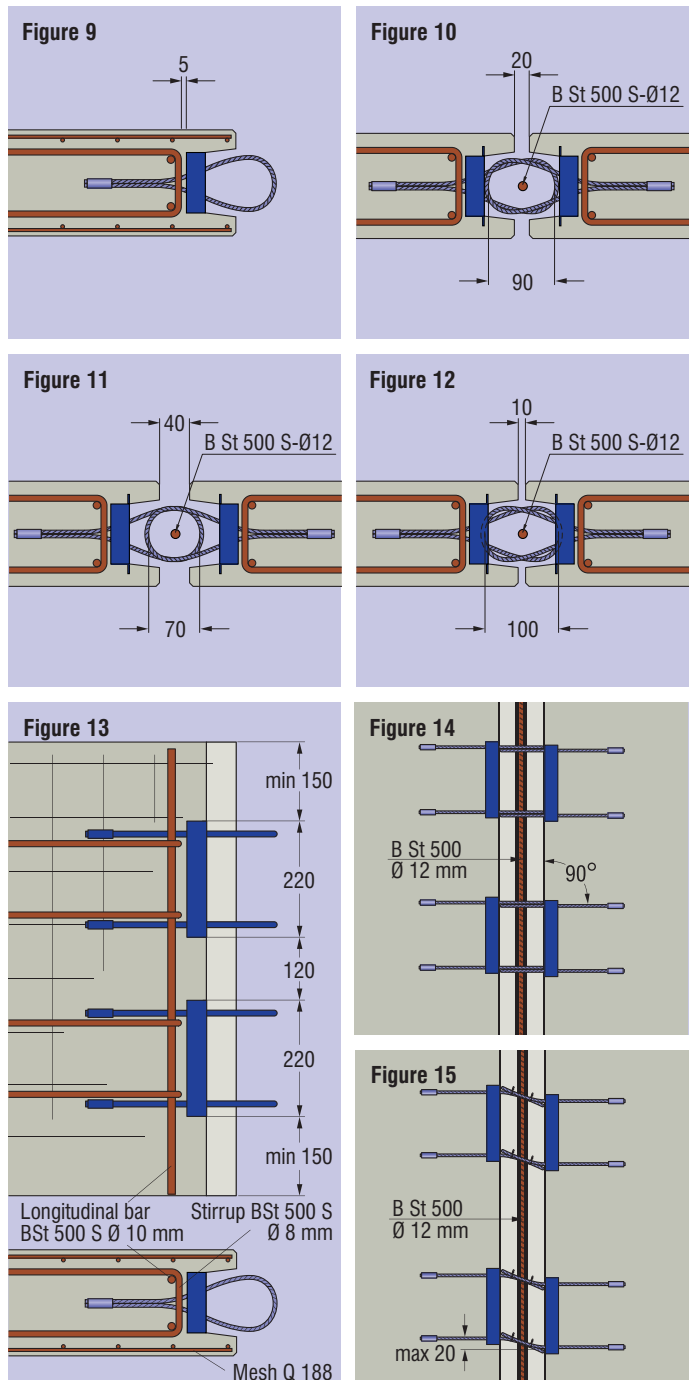

Dimensioning

The dimensioning of the steel-reinforced precast parts of standard concrete quality with strength category of at least C30/37 takes place (DIN 1045-1). The connection of the precast parts by means of the VS® Plus-Box system is dimensioned as reinforced joint with dimensioning resistances in parallel + vertical direction to the joint according to chart 1 and to dimensioning diagram (fig. 16).

In case of steel-reinforced concrete precast parts (DIN 1045-1, chart 18) the cracks width must be limited to $w_k = 0.4$ mm for indoor units (CX1) and must be limited to $w_k = 0.3$ mm for outdoor units (up to XC4). By transverse forces in parallel direction a joint can open by 0.1 mm and must be taken into account additionally to other influences.

Chart 1: Design resistances

Wall thickness [mm]	Design resistance $V_{Rd,\perp}$ [kN/m]				Design resistance $V_{Rd,\parallel}$ [kN/Box]
	C 30/37	C35/45	C 40/50	C 45/55	
180	11,9	13,5	14,5	15,4	35
200	15,0	17,1	18,4	19,6	35
220	18,4	21,0	22,5	24,0	35
≥ 240	22,0	25,0	26,9	28,6	35

$V_{Rd,\perp}$: Design resistance in vertical direction to joint

$V_{Rd,\parallel}$: Design resistance in parallel direction to joint

Transverse Force Parallel to the Joint

In the case of a pure stress with influence of transverse forces in parallel direction to the joint (fig. 17, green arrows) the connection can be dimensioned directly with the design resistance $V_{Rd,\parallel}$ according chart 1.

In the case of a pure stress with transverse forces in vertical direction to the wall plane and to the joint (fig. 17, blue arrows) the connection can be dimensioned directly according chart 1 as a function of the strength category of the concrete precast element and of the existing wall thickness. The resistance in transverse force direction vertically is determined in a very strong way by the thickness of the flanges and consequently the dependency of the wall thickness connected to that must be taken in chart 1. Only the definition range of dimensioning equations used up to now gives a limiting of the wall thickness to 240 mm.

In case of simultaneous influence of transverse forces in parallel direction and of transverse forces in vertical direction both the influences can be fully used up to certain limits according to the interaction diagram (fig. 16). Up to 1/3 of the influence in vertical direction or in parallel direction to the joint can be sustained without reducing the other influence. In case of higher simultaneous stresses the interaction according to the diagonal line (fig. 16) must be taken into account and the design resistance must be applied according to the indicated diagram.

Information on fire prevention

The PFEIFER VS® System has been assessed with respect to fire prevention in a report by the Institute of Materials Testing for Civil Engineering in Brunswick as well as in an expert opinion produced by the Technical University, Cottbus.

According to DIN 4102, Table 1, the critical temperature above which the yield point of the BSt 500 reinforcement starts to reduce under the steel tension present is $T_{crit} = 500$ °C. According to DIN 4102, for reinforcing steel in walls, a minimum axis spacing of $u = 35$ mm would be required in order to achieve F90-A. In this case, this figure refers especially to the vertical reinforcement that is at risk of buckling or to reinforcement where it is not possible to rearrange the load.

In the PFEIFER VS® System, instead of being made from reinforcing steel, the loop is made from high-tensile steel round stranded wire rope with a rated wire strength of 1770 N/mm², the strength thus corresponding to that of a stranded prestressing tendon.

From a fire prevention point of view, the VS® System, like prestressing

Figure 16

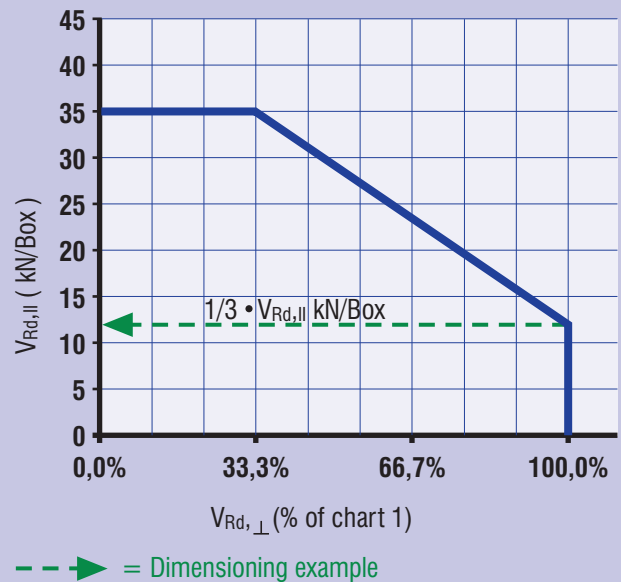

Figure 17

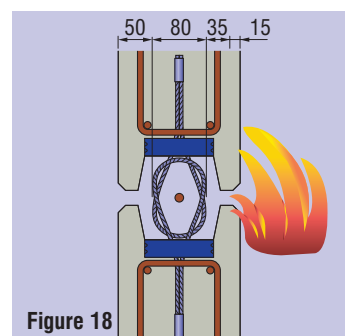
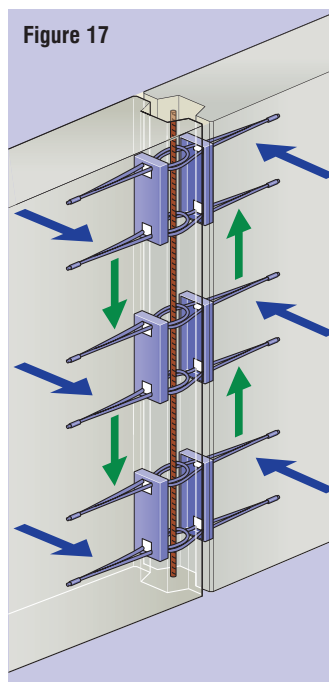

Figure 18

strands, can thus be evaluated in comparison with DIN 4102-4, 1994-03, fig. 2. Here, the critical steel temperature for these strands is $T_{crit} = 350$ °C. With regard to fire prevention, there need therefore be no concern about using the VS® System in the same way as prestressing strands. The required concrete cover must therefore be referred to a critical temperature of $T_{crit} = 350$ °C. At the same time, it should be noted that, according to DIN 4102-4, the minimum axis spacings u and u_s must be increased by a value $\Delta u = 15$ mm. Therefore, there are no concerns from the point of view of the fire-protection technics of using the VS® system like tensioning steels. Consequently, the necessary concrete cover must refer to a critical temperature $T_{crit} = 350$ °C. In this case and DIN 4102-4 it is necessary to take into account, that the minimum axial spacings u and u_s must be increased by a value $\Delta u = 15$ mm.

From this, there results e.g. the following minimum wall thicknesses in case of a fire resistance duration = 90 minutes (fig. 18):

$$d = \text{loop width}^* + 2 \times \text{concrete cover} = 70 \text{ mm} + 2 (35 \text{ mm} + 15 \text{ mm}) = 170 \text{ mm (fig. 16)}$$

Production of the Reinforced Concrete Precast Part and of the Grouting Joint

Most of the wall elements are concreted on formwork tables. A trapezoidal ledge is fixed on the frontal vertical end of the wall elements (fig. 19). The dimensions of the trapezoidal timbers are indicated in figure 20. It is important to place the bearing concrete layer thickness in central position.

When mounting the VS® Plus-Box into the formwork, it is necessary that the rope end is threaded into the reinforcement as straightly as possible. The rope end anchorings must be arranged with 90° to the joint (fig. 23). The fixing of the loops on the mesh reinforcement prevents slipping of the loops.

After that, the boxes are nailed in a simple way by beginning at the lower point of construction unit or are glued with hot adhesive to the steel formwork.

After removing the formwork

After stripping out formwork the flexible covering film is simply removed by pulling-off (fig. 21). After that, the inside of the VS® Plus-Box is free and the rope loops are visible. The rope loop can easily be tilted out (fig. 22). The rope loop must stick off vertically from the construction unit (fig. 23) and after tilting off must spring back in this position during mounting the construction units. Therefore, the loop is hooked into the integrated fixing of the steel sheet box (fig. 24). This is important for guaranteeing a perfect overlapping. At present, the wall construction units are ready for final mounting on construction site.

Mounting of the Precast Parts

The joints, the VS® Plus-Box and the loops must be clean and free from soiling or of separating humidification.

The wall construction units are set into the permissible connection type (page 6, fig. 2 up to 5) either on a mortar bed or also onto underlaid plates with different heights. The construction units must be leveled in such a way that the position and the height correspond with each other. Normally, the joint of the construction unit is 200 mm and must lie within maximum tolerance field = 10–40 mm (fig. 10 up to 12). In vertical direction, the opposite and contacting loops must be overlapping and must have a maximum spacing up to 20 mm, whereas they must then be assembled by fixing.

Preparation and Grouting of the Joints

The joints may have a height up to 3.50 m and may be grouted once. In addition, they must be grouted section by section with the help of a system consisting of funnel and hose.

When the loops are adjusted correctly an reinforcing steel of Ø = 12 mm is pushed from above through the loops (fig. 17). In this way the loops may not be separated from each other in order to guarantee the functioning of the subsequent overlapping after the grouting action. Then, the joints are closed. The joints should be cased-in against the grouting mortar pressure during filling-up of the joint by means of lateral casing boards. Filling of the joint section by section reduces the pressure accordingly.

For the preparation of the VS® Pagel® grouting and for the post-treatment we refer to page 10 and to the Pagel® working-up instructions indicated on the bags.

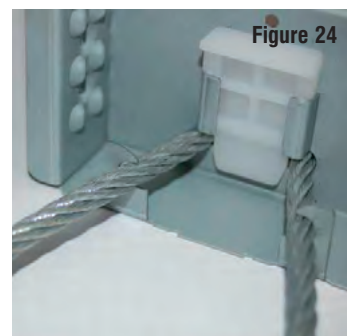
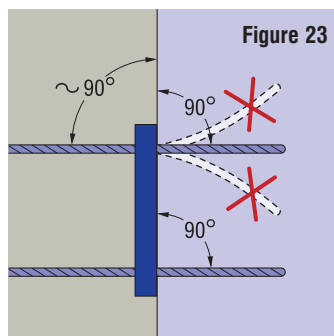
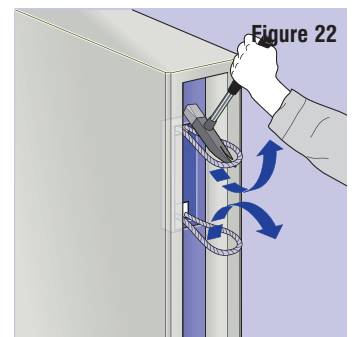
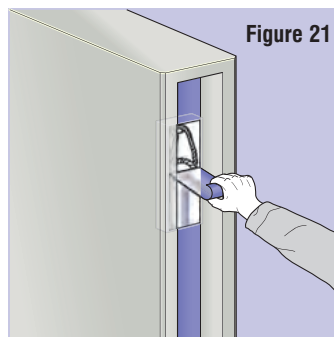
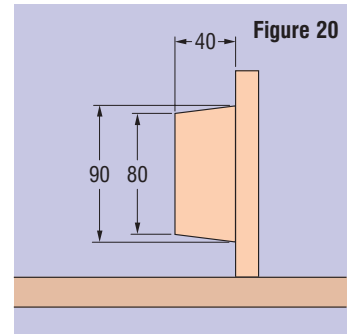
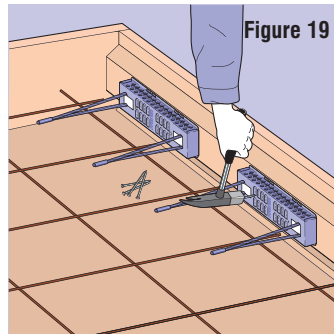

Notice:

The weakest point of the joint connection of wall construction units is always the joint grout. It is only, when the joints are grouted faultlessly and completely, and when a corresponding compacting of the joint concrete is guaranteed, that the joint connections can properly transmit the indicated forces.



Caution:

If pre-compressed tapes are pressed into the lateral joints the grouting space may not be affected. By this, the effective lateral concrete cover to the rail and to the rope loop will be reduced. This should be taken into consideration by the designer for fire-protection and corrosionproofing.

PAGEL-VS® casting mortar

Information and tips

The characteristics of the casting mortar in the joint play a significant role in producing a positive connection between concrete sections and the PFEIFER VS® System elements. We recommend the exclusive use of PAGEL-VS® casting mortar, as we have achieved very good overall results with this in the trials for the granting of the General German Technical Approval. This high-quality but inexpensive mortar combines the optimum characteristics for filling the channels in our PFEIFER VS® System and has been developed in conjunction with PAGEL GmbH & Co. KG in Essen.

Characteristics

- ✓ highly free-flowing for at least 90 minutes
- ✓ controlled volume and positive bonding
- ✓ low heat development
- ✓ low modulus of elasticity
- ✓ resistant to de-icing salt
- ✓ can be pumped and is easily workable even with mixing and feed pumps
- ✓ the casting process is carried out immediately after the ready-to-pour mixture has been made
- ✓ impermeable to water, extensively resistant to oil
- ✓ corrosion-resistant
- ✓ remote and self-monitoring production control in accordance with the "Instructions for Casting Mortar" (DBV)
- ✓ General German Technical Approval for the PAGEL concrete additive has been granted
- ✓ production certified to DIN ISO 9001
- ✓ supplied as a bagged product (bags of 25 kg) -in special cases, larger quantities in so-called BIG-BAGS with a content of 1 t are available.

Technical parameters

(according to current data sheet produced by PAGEL GmbH & Co. KG)

Aggregate size:	mm	0 – 5
Grouting height:	mm	20 – 100
max. Qty. of water:	%*	10 – 12
Amount:	kg/dm ³	2,00
Expansion:	mm	310
Working time:	at 20 °C Min.	> 120
Slump:	immediately	mm 700
	60 Min.	mm 680
Swelling value:	24 h	Vol. % + 1,0
	28 d	Vol. % + 1,0
Compressive strength:	24 h	N/mm ² 44,0
	3 d	N/mm ² 66,0
	7 d	N/mm ² 77,0
	28 d	N/mm ² 98,0
	90 d	N/mm ² 104,0
Bending strength:	24 h	N/mm ² 6,5
	3 d	N/mm ² 8,5
	7 d	N/mm ² 9,3
	28 d	N/mm ² 10,9
	90 d	N/mm ² 11,9
Modulus of elasticity 28d (cylinder):	N/mm ²	35.200

*percentage of the mass of dry mortar

The technical product data refer to an average water quantity of 11%.

- Storage:** 9 months dry and in well-sealed bags
- Form of supply:** Bags of 25 kg
- Risk category:** Non-hazardous material. Pay attention to information on packaging
- Additives:** 3.21 - 1451 Approval Certificate No. 219 000

Information for use

Preparing the base layer

Before fitting the joint shuttering or before casting the joint, the precast concrete elements contact surfaces must be pre-moistened. In the case of prefabricated reinforced concrete sections it is assumed that there is no cement slurry or any substances with a separating action present in the area of the joint. If this should be the case contrary to expectations, suitable measures must be taken to remove any contamination from the contact surfaces of the edges of the joint before fitting the joint shuttering.



Mixing PAGEL-VS® casting mortar

PAGEL-VS® casting mortar is mixed with a mechanical mixer. To make the mixture, approximately 2/3 of the maximum amount of water required is put into the mechanical mixer. After mixing for approximately 3 minutes, the rest of the water is added and mixed for a further 2 minutes. The casting process is carried out immediately after the ready-to-pour mixture has been made.

Casting the joint

The casting mortar is poured in continuously until the desired level is achieved. The casting process can be considerably simplified by using a hose and funnel system. The use of worm-driven, open feed systems is recommended for larger casting jobs. Separate working recommendations can be obtained directly from PAGEL.

Use in poor weather conditions and in difficult circumstances

According to DIN 1045, section 11, cement-bonded building materials must not be used in ambient temperatures or with component temperatures below + 5 °C, as hydration is delayed when used at lower temperatures and there is a risk of frost damage if temperatures should drop towards freezing. Frost damage can only occur however if the initial compressive strength is less than 5 N/mm².

For this reason, when working with cement-bonded building materials, it must be ensured that the component or material temperature is maintained at + 5 °C until a compressive strength of 5 N/mm² has been achieved.

With PAGEL-VS® casting mortar, a period of at least 36 hours at + 5 °C must be allowed so that this frost-resistant compressive strength is reached. Once this compressive strength has been achieved, a further increase in compressive strength follows relatively quickly.

In order to keep the heat losses from the introduced concrete as low as possible, we suggest the following options:

- Cover the fresh concrete surfaces in contact with the air with heat insulation
- Use heat-insulating shuttering
- Remove shuttering later
- Enclose the workplace

The heat-treatment measures must be carried out for at least 36 hours as otherwise there will be a risk of frost damage.

At low product temperatures the wetting of the cement particles with water takes place more slowly than at 20 °C for example. Added to this is the fact that the chemicals used for diluting (high power liquifiers) also react more slowly at low temperatures. To counteract this, we suggest the following measures:

- Extend the mixing process, be sure to use a mechanical mixer and pre-mix with 2/3 – 3/4 of the water until viscous and add the remainder of the water slowly.
- Mixing water temperature > 15 °C

- Query**
 Order tick where applicable

PFEIFER SEIL- UND HEBETECHNIK GMBH
 Geschäftsbereich BAUTECHNIK
 Postfach 1754 · D-87687 Memmingen

Fax +49 (0) 83 31-937-342

Construction project

ORDERER/INQUIRER

Company
Road
Zip code/place
Person of Contact
Phone
Fax

PFEIFER-VS®-System

PFEIFER VS® Plus-Box



VS® Pagel® Grout



The VS® Pagel® Grout is exclusively delivered by
PAGEL Spezialbeton GmbH Co.KG
 Wolfbankring 9
 45355 Essen
 Telefon 0201 685 040
 Telefax 0201 685 0431
 Mail: info@pagel.com
 Internet: www.pagel.com

Please order multiples of the packing unit in carton (400 pieces)

Item	Type	Number	Order No.	Unit price in EUR	Total price per item in EUR

The order is based on the known PFEIFER Selling and Delivery Terms.

Sum **EUR**
 plus packing and freight

Delivery address _____
 (only to be entered if different from address of orderer)

Date and signature



Lifting Anchor Systems
Thread System



Lifting Anchor Systems
BS Anchor System



Lifting Anchor Systems
WK Anchor System



Fixing Systems
Waved Anchor DB 682
for Permanent Fixings



Fixing Systems
Socket Dowels
Polyamide Sockets



Fixing Systems
HK Assembly Anchor System



Connection Systems
Column Shoe System
Wall Shoe System



Connection Systems
Steel Bearing for TT-Beams
Staircase Bearings VarioSonic



Connection Systems
Sandwich Anchor System



Connection Systems
Concrete Earthing System BEB



Reinforcement Systems
VS®-Wire Rope Loop System



Reinforcement Systems
PH Reinforcement Continuity System



Cable Tension Members
Tension Rod System



Attachment Materials
(Wire Ropes, Chains, Textiles)



Lashing Systems



Grabs for Reinforcing Steel



Balancing Spreader Beams

Headquarters

PFEIFER SEIL- UND
HEBETECHNIK GMBH
Dr.-Karl-Lenz-Strasse 66
D-87700 MEMMINGEN
Telefon +49 (0)8331-937-312
Telefax +49 (0)8331-937-342
E-Mail export-bt@pfeifer.de
Internet www.pfeifer.de

Our products are sold by



J&P: Die Baupartner.

in Germany

Nobelstraße 51-55
D-12057 BERLIN
Tel. 030-68283-02
Fax 030-68283-497
E-Mail info@jordahl.de
Internet www.jordahl.de
Am Güterbahnhof 20
D-79771 KLETTGAU
Tel. 07742-9215-20
Fax 07742-9215-90
E-Mail klettgau@jp-bautechnik.de
Internet www.h-bau.de

Stettiner Straße 20
30916 ISERNHAGEN/Hannover
Tel. 0511-61779
Fax 0511-614604
E-Mail jp-hannover@pfeifer.de

Oeseder Straße 115
D-49124 GEORGSMARIENHÜTTE/
Osnabrück
Tel. 05401-871544
Fax 05401-871540
E-Mail jp-osnabrueck@pfeifer.de

Fundlandstraße 29
D-45326 ESSEN
Tel. 0201-28966-0
Fax 0201-28966-20
E-Mail jp-essen@pfeifer.de

Zum Wiesengrund 2
D-01723 KESSELSORF/Dresden
Tel. 035204-215-11
Fax 035204-215-18
E-Mail jp-dresden@pfeifer.de

Markircher Straße 14
D-68229 MANNHEIM
Tel. 0621-4840340
Fax 0621-4840344
E-Mail jp-mannheim@pfeifer.de

Lechstraße 21
D-90451 NÜRNBERG
Tel. 0911-6427808
Fax 0911-6428472
E-Mail jp-nuernberg@pfeifer.de

Hölderlinstraße 23
D-75446 WIERNISHEIM/Stuttgart
Tel. 07041-860858
Fax 07041-2239
E-Mail jp-stuttgart@pfeifer.de

in Denmark

J&P BYGGTEKNIK A/S
Risgårdevej 66, Risgårde
DK-9640 FARSØ
Tel. +45-9863-1900
Fax +45-9863-1939
E-Mail info@jordahl-pfeifer.dk

in Austria

GHL Bautechnik
Produktions- und Handels GmbH
Caracallastraße 16
A-4470 ENNS
Tel. +43-7223-81919-0
Fax +43-7223-81919-33
E-Mail office@ghl-bau.at

in Switzerland

ANKABA Ankertechnik und Bauhandel AG
Zürichstr. 38a
CH-8306 BRÜTTISELLEN
Tel. +41-44-807 17 17
Fax +41-44-807 17 18
E-Mail info@ankaba.ch

in Czechia

J&P STAVEBNÍ TECHNIKA s.r.o.
Prumyslová 5
CZ-10821 PRAHA 10
Tel. +420-272700701
Fax +420-272703737
E-Mail info@jpcz.cz

in Poland

J&P TECHNIKA BUDOWLANA Sp. z o.o.
ul. Wroclawska 68
PL-55-330 KREPICE k/Wroclawia
Tel. +48-71-3968264
Fax +48-71-3968105
E-Mail biuro@jordahl-pfeifer.com.pl

in Hungary

PFEIFER GARANT Kft.
Gyömrői út 128
HU-1103 BUDAPEST
Tel. +36-1-2601014
Fax +36-1-2620927
E-Mail info@pfeifer-garant.hu

in Singapore

J&P BUILDING SYSTEMS PTE LTD.
No. 48 Toh Guan Road East
#08-104 Enterprise Hub
SG-SINGAPORE 608586
Tel. +65-6569-6131
Fax +65-6569-5286
E-Mail jandpsgp@singnet.com.sg

in the UAE

Emirates German Building Materials
Trading (LLC)
Al Quasais Ind. Area –
4, Beirut St.
UAE-DUBAI
Tel. +971-4-2676644
Fax +971-4-2676646
E-Mail gemirate@emirates.net.ae

in Spain

J&P TÉCNICAS DE ANCLAJE S.L.
Avda. de los Pirineos, 25 – Nave 20
San Sebastián de los Reyes
ES-28700 MADRID
Tel. +34-916593185
Fax +34-916593139
E-Mail jp@anclajes.com
ES-08820 BARCELONA
Tel. +34-93-3741030
Fax +34-93-3741459

in the United Kingdom/Ireland

J&P BUILDING SYSTEMS Ltd.
Unit 5 Thame Forty
Jane Morbey Road
GB-THAME, OXON OX9 3RR
Tel. +44-1844-215200
Fax +44-1844-263257
E-Mail enquiries@jandpbuildingsystems.com

in Russia

000 PFEIFER
KANATI & PODJÖMNIJE TEHNOLOGII
RU-111141 MOSCOW
3rd proezd Perova Poly. 8
Tel. +7-495-505-74-94
Fax +7-495-363-00-73
E-Mail info@pfeiferrussia.ru
ST. PETERSBURG
Tel. +7-812-740-12-24
Fax +7-812-740-12-24

in Romania

S.C. JORDAHL & PFEIFER
TEHNICA DE ANCORARE S.R.L.
str. Malului nr. 7 Et.1
RO-550197 Sibiu jud. Sibiu
Tel. +4 0269 246 098
Fax +4 0269 246 099
E-Mail info@jordahl-pfeifer.ro

► For all other export countries please contact our headquarters in Germany.