

PFEIFER

SEILBAU ■ CABLE STRUCTURES



PFEIFER-Tension Rod System Type 860

PFEIFER
SEIL- UND HEBETECHNIK
GMBH

DR.-KARL-LENZ-STRASSE 66
D-87700 MEMMINGEN
TELEFON +49 (0)8331-937-393
TELEFAX +49 (0)8331-937-350
E-MAIL zugglieder@pfeifer.de
INTERNET www.pfeifer.de

PFEIFER**PFEIFER proudly presents:****■ The aesthetically designed
High-Performance
Tension Rod System Type 860**

- with German Technical Approval including approval for use as:
 - compression member
 - end fitting for cables
- complete high-quality Tension Rod System with appealing aesthetic design
- large product range:
 - rod diameters from 10 to 100 mm
 - maximum rod length 15 m
- high-strength Tension Rod with a maximum limit tension load of up to 2,900 kN
- slender and economical components
- large take-up range
- hot-dip galvanized components
- with a variety of useful accessories

PFEIFER
Seil- und Hebeteknik GmbH
Dr.-Karl-Lenz-Strasse 66
D-87700 Memmingen

**Zulassungs-Nr.
Z-14.4-433**

PFEIFER-Zugstabsystem 860

IS
Institut für Stahlbau
TU Braunschweig

Competence resulting from experience

■ For many years, **PFEIFER-Tension Members** have proved their mettle in hundreds of buildings all over the world. The German Technical Approval granted by the Berlin-based Deutsches Institut für Bautechnik (German Institute for Construction Engineering) has made realisation even easier. Now you can use tension members without having to undergo time-consuming and costly approval procedures.

■ The multitude of connection details and their elaborate architectural design make it possible for you to find a fitting and appealing solution for almost all practical applications.

■ Whether you intend to realize your project with cables or Tension Rods, you will definitely profit from the safety and the experience of the market leader if you use **PFEIFER-Tension Members**.



The proven range of Cable Tension Members:



fork connector
Type 802

stainless-steel open
swaged socket Type 961

fitting with thread
Type 968



1 Trade Fair Hall 9 in
Hanover, Germany

2 Company Boehringer in
Ingelheim, Germany

3 Pedestrian bridge of the company
SAP in Walldorf, Germany

Economical use of **PFEIFER-Tension Members** is possible in a variety of engineering areas, for example for:

- Header ties
- Façade suspensions
- Pylon bracings
- Canopy guying
- Truss systems

PFEIFER-Tension Members allow for slender and aesthetically appealing design and function and they can be easily combined with the entire range of materials used in modern architecture, such as steel, wood and glass.

When designing a construction, the planner of load-bearing structures can profit from the principle of load diversion via tension and compression elements, and at the same time, clear and interesting architectural forms are created.

Bracing

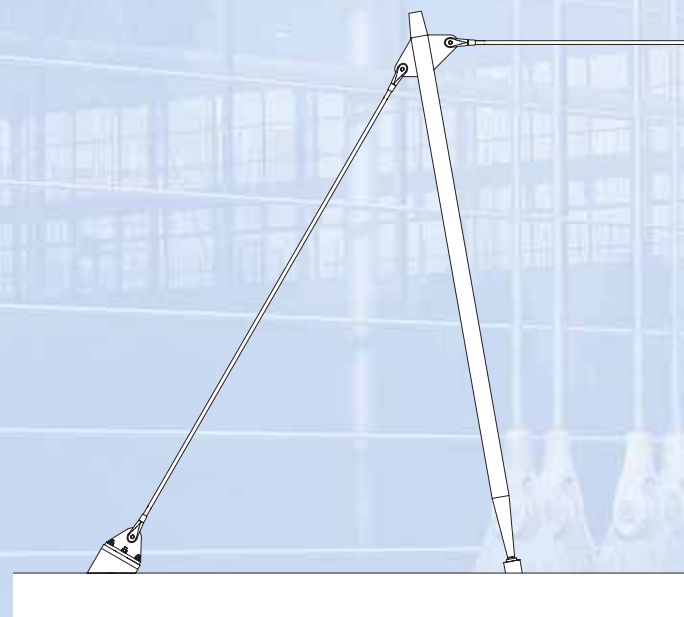

Ties

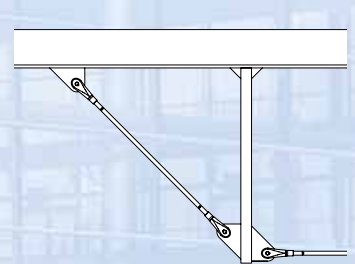

Intersection plate

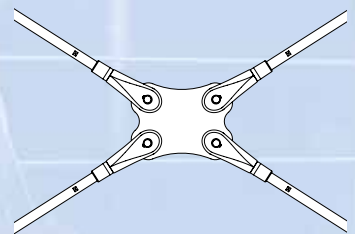

Technology

The PFEIFER-Tension Rod System Type 860 consists of a Tension Rod, the fork connector and the components of the latter; furthermore special components are available. The PFEIFER-Tension Rod System Type 860 was statically designed pursuant to German standard DIN 18800 Part 1/11.90. Said design was confirmed by an expertise.

■ Tension Rod

The Tension Rod is made of the material S460N with a yield strength of at least 460 N/mm², thus approximately 30% higher than that of the conventional material S355. Consequently, the same loads can be taken up with a smaller rod diameter. The Tension Rod has a slender design and economic efficiency is increased.

The limit tension loads resulting from design can be seen from the product tables below. For calculation they have to be at least as high as the design values of impacts (F_d). Intersection plates and connecting plates made of the material S355 are used as connecting points. Their geometrical design guarantees full load-bearing capacity as regards the limit tension loads ($N_{R,d}$) listed in the product tables below. If intersection plates and connecting plates are made of S235, the reduced limit tension loads ($N_{R,d,red}$) can also be taken from the product tables below.

■ Components

The Tension Rod is the weakest link in the Tension Rod System. Thus, fork connectors, pins and couplers are designed to withstand higher loads so as to preclude failure of these components. Locking nuts that safely lock fork connector and Tension Rod as well as Tension Rod and coupler, respectively, are supplied. Furthermore, the locking nut protects the thread of the Tension Rod and provides for flush contours between fork connector and Tension Rod and between Tension Rod and coupler, respectively.

■ Special Components

Adapters, compression rods and cable tension members are also available as special components with German Technical Approval.

■ Adjustment Options

The left-hand and right-hand threads of the fork connectors enable exact adjustment of length, which is done by turning the Rod. No turnbuckle is required. The take-up range can be comfortably adjusted by approximately 1.4 times the thread diameter for all sizes per system length. System length is the distance between the centres of the pins.

■ Corrosion Protection

All elements of PFEIFER-Tension Rod System Type 860 are protected from corrosion either by hot-dip galvanisation pursuant to German standard DIN EN ISO 1461 or by metal spraying of zinc pursuant to German standard DIN EN 22063. All threads are brushed after galvanisation.



Tension Rod

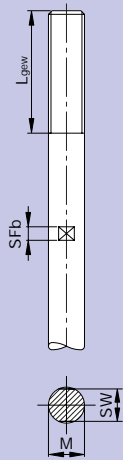

Mat.	S460N						Weight kg/m
M mm	N _{R,d} * kN	N _{R,d,red} ** kN	L _{gew} mm	SFb mm	SW mm	L _{max} mm	
10	26,3	26,3	33	10	9	6000	0,61
12	38,3	38,3	38	12	10	6000	0,88
16	71,2	60,1	54	15	14	15000	1,58
20	111	93,9	67	18	18	15000	2,47
24	160	160	80	23	22	15000	3,55
27	208	167	90	23	25	15000	4,50
30	254	254	100	28	28	15000	5,55
36	371	260	120	28	33	15000	8,00
42	509	359	140	33	39	15000	10,9
48	669	488	159	38	45	15000	14,2
52	798	638	172	43	49	15000	16,7
56	922	638	187	43	53	15000	19,3
60	1073	807	199	48	57	15000	22,2
64	1215	997	211	53	60	15000	25,3
70	1463	1206	233	58	65	15000	30,2
80	1910	1685	266	68	75	15000	39,5
90	2418	2243	297	78	85	15000	49,9
100	2985	2552	328	83	95	15000	61,7

Subject to technical modifications

*Limited tension load according to DIN 18800 connecting plate S355J2G3 ** connecting plate S235J2G3

Fork connector

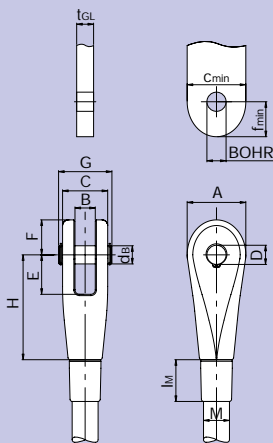

Mat.	Fork connector EN-GJS-400-18-LT								Pin 34CrNiMo6V		Lock nut I _M mm	connecting plate S355J2G3 und S235J2G3				Total weight kg
	M mm	A mm	B mm	C mm	D mm	E mm	F mm	H mm	d _B mm	G mm		t _{GL} mm	f _{min} mm	c _{min} mm	BOHR mm	
10	25	10	20	10	19	16	52	9	27,0	21	8	16	25	10	0,12	
12	29	12	24	11	21	18	58	10	31,0	25	10	17	29	11	0,20	
16	42	15	32	15	30	26	77	14	41,0	33	12	23	42	15	0,53	
20	52	18	40	17	35	31	93	16	50,2	41	15	27	52	17	0,95	
24	58	23	48	23	46	39	115	22	59,8	49	20	36	58	23	1,57	
27	68	23	54	25	47	44	125	24	66,6	55	20	39	68	25	2,34	
30	77	28	60	29	52	51	138	28	74,8	62	25	47	77	30	3,14	
36	90	28	72	33	64	58	167	32	89,3	74	25	53	90	34	5,57	
42	104	33	84	37	70	66	190	36	103	86	30	59	104	38	8,74	
48	120	38	96	41	78	74	213	40	118	99	35	66	120	42	12,7	
52	136	43	104	46	85	84	231	45	126	107	40	73	136	47	16,5	
56	148	43	112	51	95	91	254	50	138	115	40	81	148	52	21,9	
60	162	48	120	56	106	100	275	55	146	124	45	90	162	58	27,1	
64	170	53	128	56	107	103	286	55	154	132	50	90	170	58	31,6	
70	185	58	140	61	117	113	315	60	166	144	55	98	185	63	39,3	
80	210	68	160	71	133	132	359	70	187	165	65	114	210	73	58,6	
90	240	78	180	80	150	150	402	79	211	185	75	128	240	82	85,5	
100	265	83	200	90	170	165	448	89	232	205	80	144	265	92	120,5	

Subject to technical modifications

Fork connector with adapter

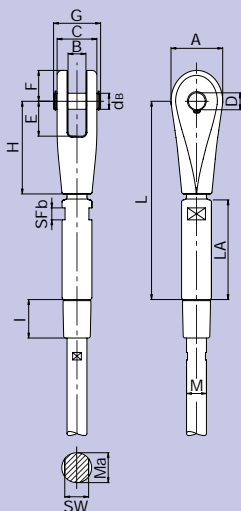

Mat.	Fork connector EN-GJS-400-18-LT								Pin 34CrNiMo6V		Lock nut I _M mm	Adapter S460N				Total weight kg
	M mm	A mm	B mm	C mm	D mm	E mm	F mm	H mm	d _B mm	G mm		LA mm	L mm	Ma mm	SW mm	
10	25	10	20	10	19	16	52	9	27,0	21	50	105	15	12	6	0,19
12	29	12	24	11	21	18	58	10	31,0	25	60	122	18	14	7	0,32
16	42	15	32	15	30	26	77	14	41,0	33	80	161	24	19	10	0,82
20	52	18	40	17	35	31	93	16	50,2	41	100	198	30	24	12	1,52
24	58	23	48	23	46	39	115	22	59,8	49	115	236	37	30	14	2,57
27	68	23	54	25	47	44	125	24	66,6	55	130	261	41	32	16	3,73
30	77	28	60	29	52	51	138	28	74,8	62	140	285	45	36	18	4,95
36	90	28	72	33	64	58	167	32	89,3	74	170	345	54	46	22	8,75

Subject to technical modifications

Tension Rod System

M mm	min ~L _{sys} mm	max L _{sys} mm	Take up ±mm
10	196	6063	14
12	226	6071	12
16	294	15087	23
20	359	15103	29
24	436	15131	35
27	479	15139	40
30	530	15153	43
36	643	15186	52
42	734	15207	61
48	823	15228	68
52	895	15249	75
56	973	15276	82
60	1045	15305	85
64	1098	15311	89
70	1203	15343	101
80	1374	15390	116
90	1527	15436	128
100	1692	15489	141

Subject to technical modifications

Tension Rod System with one coupler

M mm	min ~L _{sys} mm	max L _{sys} mm	Take up ±mm
10	347	12081	28
12	399	12080	24
16	528	30114	46
20	645	30134	58
24	777	30168	70
27	863	30182	79
30	955	30202	86
36	1160	30245	104
42	1329	30275	122
48	1496	30306	136
52	1624	30332	150
56	1763	30369	164
60	1885	30405	170
64	1987	30414	178
70	2177	30458	202
80	2486	30518	232
90	2762	30580	256
100	3054	30648	282

Subject to technical modifications

Tension Rod System with two couplers

M mm	min ~L _{sys} mm	max L _{sys} mm	Take up ±mm
10	497	18098	42
12	573	18109	36
16	762	45141	69
20	932	45165	87
24	1119	45205	105
27	1246	45226	119
30	1381	45251	129
36	1676	45304	156
42	1923	45343	183
48	2169	45384	204
52	2353	45415	225
56	2552	45461	246
60	2725	45505	255
64	2877	45518	267
70	3152	45573	303
80	3598	45646	348
90	3997	45724	384
100	4416	45807	423

Subject to technical modifications

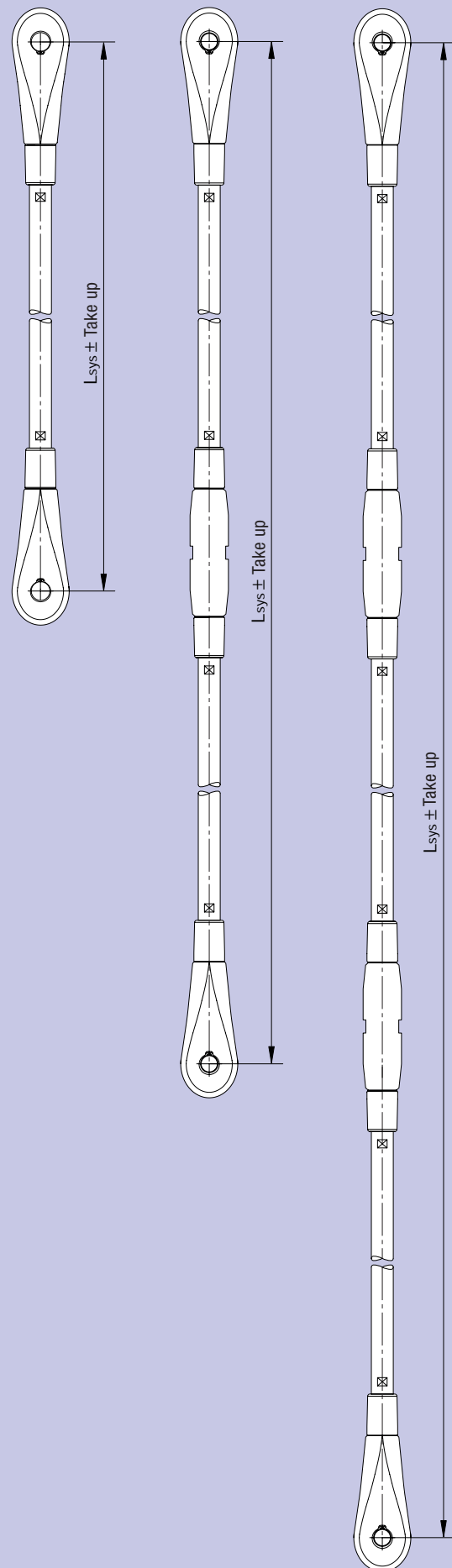

Intersection plate with connection angle 40°-55°

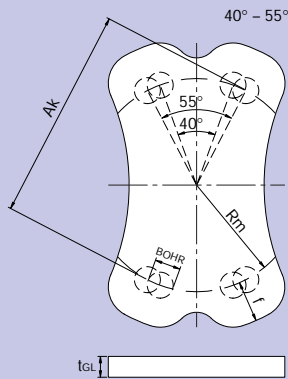

Mat.	S355J2G3					
M mm	t _{GL} mm	BOHR mm	Rm mm	f mm	Ak mm	Weight kg
10	8	10	41	16	82	0,37
12	10	11	53	17	106	0,67
16	12	15	71	23	142	1,54
20	15	17	86	27	172	2,77
24	20	23	99	36	198	5,13
27	20	25	114	39	228	6,86
30	25	30	131	47	262	11,4
36	25	34	153	53	306	15,1
42	30	38	171	59	342	22,9
48	35	42	194	66	388	34,7
52	40	47	219	73	438	49,8
56	40	52	236	81	472	57,9
60	45	58	260	90	520	80,2
64	50	58	283	90	566	101,5
70	55	63	313	98	626	131,8
80	65	73	352	114	704	200,9
90	75	82	390	128	780	291,2
100	80	92	425	144	850	373,2

Subject to technical modifications

Intersection plate with connection angle 55°-75°

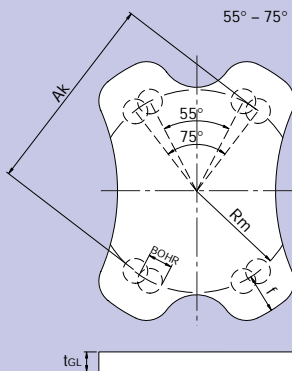

Mat.	S355J2G3					
M mm	t _{GL} mm	BOHR mm	Rm mm	f mm	Ak mm	Weight kg
10	8	10	41	16	82	0,41
12	10	11	53	17	106	0,79
16	12	15	71	23	142	1,76
20	15	17	86	27	172	3,19
24	20	23	99	36	198	5,85
27	20	25	114	39	228	7,64
30	25	30	131	47	262	12,8
36	25	34	153	53	306	17,3
42	30	38	171	59	342	26,5
48	35	42	194	66	388	39,7
52	40	47	219	73	438	57,0
56	40	52	236	81	472	66,7
60	45	58	260	90	520	92,5
64	50	58	283	90	566	114,9
70	55	63	313	98	626	152,7
80	65	73	352	114	704	233,2
90	75	82	390	128	780	334,3
100	80	92	425	144	850	432,8

Subject to technical modifications

Intersection plate with connection angle 75°-90°

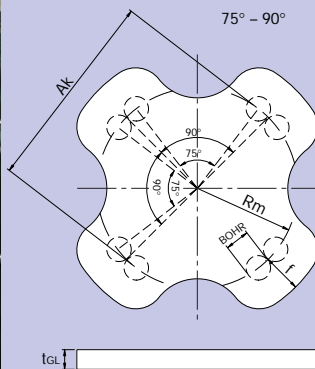

Mat.	S355J2G3					
M mm	t _{GL} mm	BOHR mm	Rm mm	f mm	Ak mm	Weight kg
10	8	10	41	16	82	0,46
12	10	11	53	17	106	1,82
16	12	15	71	23	142	1,78
20	15	17	86	27	172	3,31
24	20	23	99	36	198	6,03
27	20	25	114	39	228	7,91
30	25	30	131	47	262	13,3
36	25	34	153	53	306	18,0
42	30	38	171	59	342	27,2
48	35	42	194	66	388	41,1
52	40	47	219	73	438	58,8
56	40	52	236	81	472	69,0
60	45	58	260	90	520	95,0
64	50	58	283	90	566	119,9
70	55	63	313	98	626	159,0
80	65	73	352	114	704	240,5
90	75	82	390	128	780	346,8
100	80	92	425	144	850	446,5

Subject to technical modifications

Coupler

Mat.	S355J2G3					
M mm	L mm	d_M mm	SFb mm	SW mm	Weight kg	
10	58	17	7	15	0,07	
12	72	19	7	17	0,10	
16	94	28	11	24	0,31	
20	116	35	12	30	0,60	
24	138	42	14	36	1,04	
27	156	48	15	41	1,51	
30	172	51	16	46	1,88	
36	207	65	17	55	3,69	
42	242	75	19	65	5,74	
48	273	88	21	75	8,80	
52	295	92	22	80	10,4	
56	321	98	24	85	12,8	
60	341	105	25	90	15,5	
64	362	109	27	95	17,9	
70	400	128	27	110	27,7	
80	456	144	30	125	39,1	
90	508	163	36	140	55,5	
100	560	174	39	155	69,0	

Subject to technical modifications

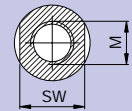
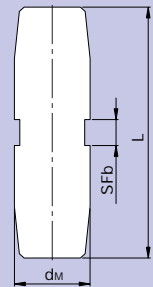

Spiral strand galvanized coated
1 x 37, 1x 61

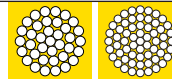

Nominal-diameter	Construction	metallic cross section	minimal breaking load* f _{u,k} = 1670 N/mm ² bei k _e = 0,9	limit tension* Z _{R,d} DIN 18800 bei k _e = 0,9	Weight
ds (mm)		mm ²	kN	kN	kg/m
10	1 x 37	58,9	77,0	46,7	0,489
12	1 x 37	84,8	110,8	67,2	0,704
14	1 x 37	115,0	150,9	91,5	0,958
16	1 x 37	151,0	197,0	119,5	1,25
18	1 x 37	191,0	249,0	151,2	1,58
22	1 x 37	285,0	372,0	225,9	2,37
26	1 x 61	398,0	521,0	316,0	3,27
30	1 x 61	530,0	693,0	420,0	4,35
32	1 x 61	603,0	788,0	478,0	4,95
34	1 x 61	681,0	890,0	540,0	5,58
36	1 x 61	763,0	998,0	605,0	6,26

Subject to technical modifications

* with swaged end termination

certification-number: Z-14.7-413
module of elasticity: 150 ± 10 kN/mm²
Tolerance d_s: + 5%
Corrosion protection:
galvanized coated without inner filling

Fork connector with fitting with thread

Mat.	Fork connector							Pin		Fitting with thread						Lock nut	Total weight
	EN-GJS-400-18-LT							34CrNiMo6V		S355J2G3							
M mm	A mm	B mm	C mm	D mm	E mm	F mm	H mm	d _B mm	G mm	L mm	Ver. ±mm	D _V * mm	D _{Vmax} * mm	SW mm	d _s mm	l _M mm	kg
16	42	15	32	15	30	26	77	14	41,0	219,5	11,5	19	22	17	10	13	0,77
20	52	18	40	17	35	31	93	16	50,2	254,5	14,5	22,2	26	19	12	16	1,37
24	58	23	48	23	46	39	115	22	59,8	318,5	17,5	26	30	22	14	19	2,28
27	68	23	54	25	47	44	125	24	66,6	348,3	20,0	30	34	24	16	22	3,36
30	77	28	60	29	52	51	138	28	74,8	380,5	21,5	34	39	30	18	24	4,63
36	90	28	72	33	64	58	167	32	89,3	475,0	26,0	40	46	32	22	29	8,18
42	104	33	84	37	70	66	190	36	103	560,5	30,5	48	55	43	26	34	13,0
48	120	38	96	41	78	74	213	40	118	645,0	34,0	56	64	46	30	38	19,7
52	136	43	104	46	85	84	231	45	126	686,5	37,5	58	66	50	32	42	24,7
56	148	43	112	51	95	91	254	50	138	748,0	41,0	62	71	50	34	45	32,0
60	162	48	120	56	106	100	275	55	146	790,5	42,5	66	75	55	36	48	39,2

Subject to technical modifications

* after swaging

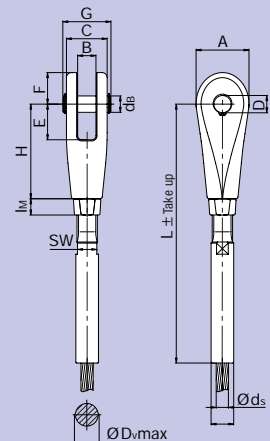

Construction aids

The following construction aids for the PFEIFER-Tension Rod System Type 860 shall illustrate the formation of connecting points and the structural alignment of the Tension Rod System.

■ Connecting Points

In the case of connecting points attention must be paid to the orientation of the system axes of all abutting components. The axes of load diversion and load transmission have to intersect in exactly one point. The connecting plates have to be designed and manufactured in keeping with the diameter of bore, the minimum distance f_{\min} between the centre of bore and the apex of the connecting plate, the minimum width c_{\min} as listed in the table "Fork Connector", a connection edge that is parallel to the fork base and the necessary material quality (see Fig. 1).

An estimate of the connecting-plate dimensions can be made on the basis of the connection angle and via the geometric proportions of the diameter of bore (see Fig. 2).

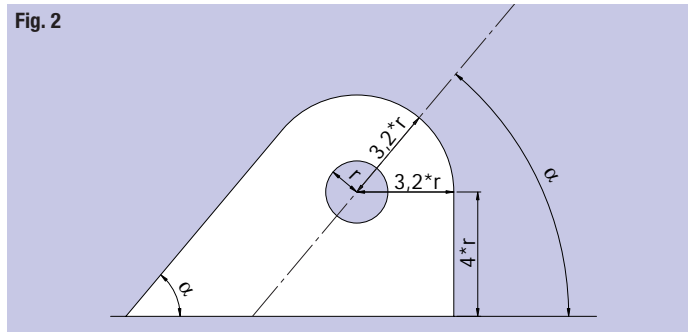
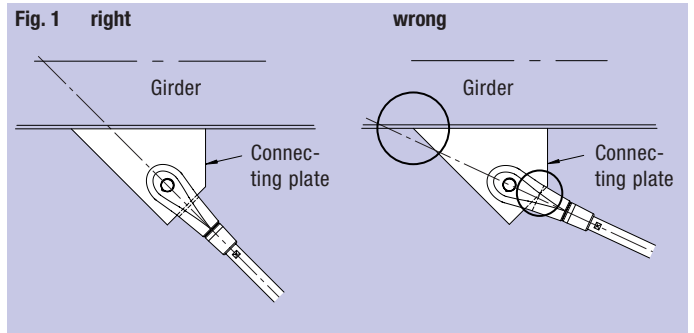

■ Structural Alignment

During installation of the Tension Rod System, care must be taken to ensure that any misalignment is avoided. Alignment of the entire system must not deviate from its plane by more than 0.5° . Otherwise, non permissible bending tensions are introduced into both the fork connectors and the connecting plates (see Fig. 3). Especially during installation of a Tension Rod with connections that are offset towards each other, precise structural orientation (alignment) must be ensured (see Fig. 4 and Fig. 5).

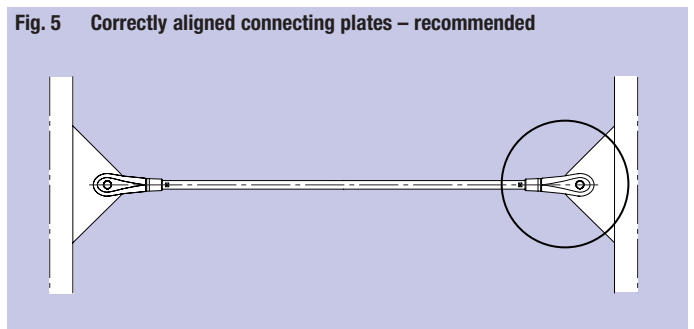
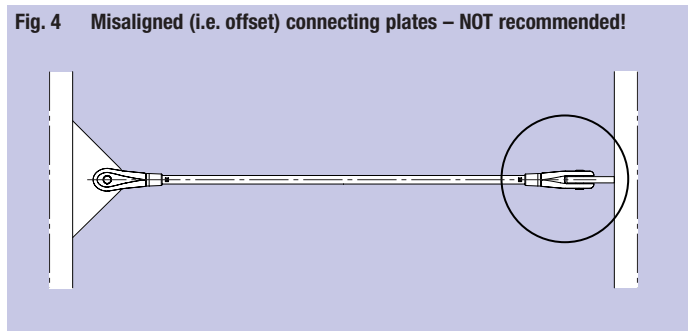
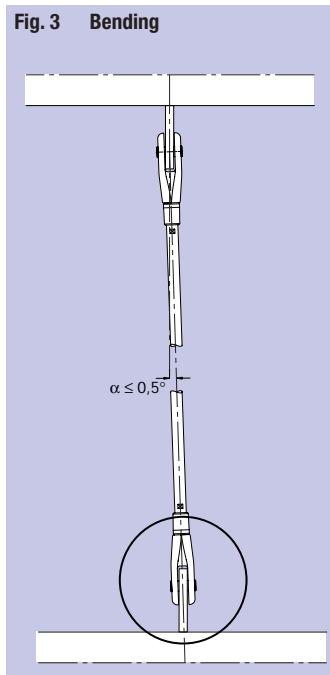

Additional Information

■ Delivery and Installation

The PFEIFER-Tension Rod System Type 860 is pre-assembled so as to facilitate installation (see Fig. 6).

For installation the length of the Tension Rod System has to be adjusted to the system length by turning the Tension Rod and by aligning it such that the pin can be inserted without bending (see Fig. 7). Driving in the pin with a hammer is forbidden since it can cause damage to the fork connector!

The Tension Rod System is adjusted with a spanner. If used correctly, adjustable spanners and screw wrenches (monkey wrenches) can also be practical. Special-design spanners are available on request. The locking nuts are then screwed back towards the Fork Connector until they are locked. A strap wrench can be used to tighten the locking nut so as to avoid damaging the surface (see Fig. 8).

In the scope of building supervision the minimal thread reach has to be checked for each fixing insert by appropriate measures. Checks have to be documented and recorded by the responsible head of installation or chief erector. The minimal thread reach is achieved when the rod thread is completely covered by the locking nut. If threads with a special length are used, appropriate measures have to be taken to ensure that the minimal thread reach is achieved.

If the galvanized surface is damaged during tightening, the damaged spots have to be repaired professionally so as to guarantee the necessary corrosion protection.

If the system length exceeds 10 m, the Tension Rod System has to be supported and stabilized with at least two round slings since otherwise the entire system is susceptible to buckling.

■ Information about Inquiry or Ordering

The diameter of the Tension Members has to be taken from the table of Tension Rod parameters or the table of Tension-Cable parameters in dependence on the limit tension ($N_{R,d}$). The required limit tension results from structural calculation.

When indicating the system length (L_{sys}), the minimum length, that is the shortest producible length, of the respective Tension Member has to be considered (see Fig. 9).

Additional specifications, such as partial lengths L_1 and L_2 that have to be taken into consideration have to be entered into the field "Comments" on the order form (see Fig. 10 and Fig. 11).

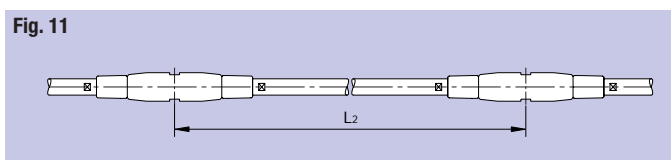
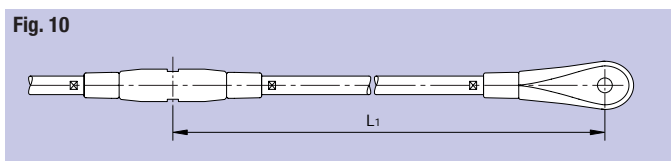
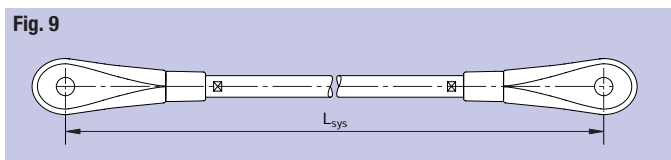
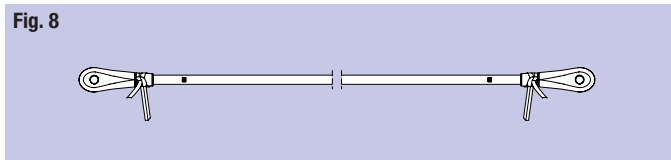
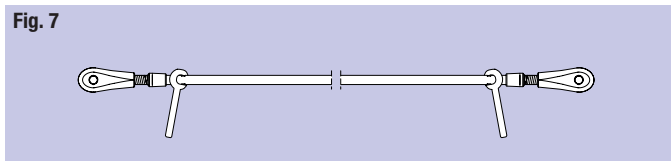
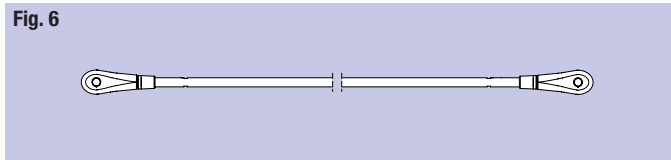

General Conditions of Business

PFEIFER SEIL- UND HEBETECHNIK GMBH

1. GENERAL CONDITIONS

1.1 Supplies and performances are exclusively carried out on the basis of the following conditions. Purchasing conditions of the customer are herewith rejected.

1.2 Our quotations are not binding, contracts and any other agreements only become binding after being confirmed by us in writing.

2. PRICE AND PAYMENT TERMS

2.1 Unless otherwise agreed our prices are to be understood ex works plus VAT if to be added according to the regulations of the sales tax law and the ones of the European Community. We reserve the right to increase prices of contracts with an agreed delivery time of more than four months in accordance with increased costs resulting from collective agreements and increased material or additional costs.

2.2 Payments have to be made within 30 days from date of shipment ex works on net terms only. Cash discounts are subject to prior agreement and are only granted if the customer is not in default of payment of any other invoice. Late payments are charged interest of 5 % above the discount rate of the Federal Bank of Germany.

2.3 The customer may only offset payments against indisputable and legally valid claims after having given an one month written notice in advance. The right to withhold payments may only be exercised if based on the same contractual relationship.

2.4 If payments are endangered by a customer's financial setback after signing of contract we are entitled to claim immediate payment. This applies also for any drafts irrespective of their maturity dates. Default of payment entitles us to take back the goods and should the situation arise to enter the customer's company in order to seize the goods. We may also forbid the processing of supplied goods. These conditions cease to be in force if the customer is not responsible for the default of payment. The taking back of goods does not represent a withdrawal from contract.

In both cases we may revoke the collection authority acc. to clause no 7.7 and ask advance payment for still undelivered goods. All legal consequences are avoidable if the customer offers a surety amounting to the total value of the claim.

2.5 We are entitled to sureties corresponding to the nature and volume of our claims even if they are limited or restricted in time.

2.6 Legal regulations concerning the default of payment remain unaffected.

2.7 We are entitled to offset all our claims concerning the customer – whatever the legal justification may be – against the ones the customer may have against us. This can also be done if one party has agreed on cash settlement and the other one on drafts or any other kind of payment. If necessary the agreements only concern the balance. In case of different settlement dates our claims become due for payment latest on settlement date of our liabilities.

2.8 We reserve the right to charge a handling fee of EUR 25,- on all orders up to EUR 100,- as minimum order value.

3. DIMENSION, WEIGHT AND QUALITY

3.1 Norm indications always refer to the latest version.

3.2 Tolerances in dimension, weight and quality are allowed if in accordance with the DIN-standard or general practice.

3.3 Technical data and description of items to be delivered are not binding. We reserve the right for any reasonable technical modification of a product. All costs estimates, drawings and any other documents remain our property and copyright. It is prohibited to disclose them to any third party and they must be returned if the purchase order is not placed with us.

3.4 All details concerning products and dimensions are non-warranted properties and represent quality statements without obligation.

4. SHIPMENT AND PASSING OF RISK

4.1 Choice of transport route and means as well as of the transport agent or carrier is up to us if no contrary instructions are given by the customer.

4.2 If loading or shipment of goods is delayed by the customer we are entitled to store them at his expense and risk as well as to take appropriate steps for their preservation and to invoice them like shipped ones. The same applies to goods for which request of delivery has not been received within 4 days after notification that they are ready for shipment. Regulations about taking delivery in due time remain unaffected.

4.3 The customer has to inform us immediately if goods are damaged in transit and see to it that the forwarding agent reports on the facts.

4.4 At the time goods are taken over by the transport agent or carrier, latest however when goods leave the factory or warehouse, the risk is passed on to the customer.

4.5 Incoterms 1990 are the rules for the interpretation of trade terms.

4.6 We are allowed to make partial shipments. The customer commits himself to accepting and paying a partial shipment if reasonable and not interfering with any of his contractual rights.

4.7 If not agreed otherwise goods are shipped unpacked and unprotected against rust. Packing material made of paper, PVC, jute, etc. as well as non-returnable reels and pallets are not taken back. Reels on loan are invoiced and must be fully paid. If returned to us in good condition within 2 months they will be credited to the customer's account with two thirds of the value invoiced.

4.8 For assembly and erection works our travel allowances and expenses for journey and stay have to be reimbursed. The customer has to make sure that the works can be carried out without interruption and all preliminary works like foundations, electric connections and suchlike will be at our disposal free of charge.

5. DELIVERY TIME AND DELAYED SHIPMENT

5.1 Agreed delivery times are only valid on condition that all order details have been clarified in time and the customer has fulfilled all his obligations. On expiry of the agreed delivery time an extension is granted without further notice. It shall be of the same time as the original delivery time however not longer than 21 days. Only after expiry of the extended delivery time, we can be put in delay.

5.2 If the customer does not timely fulfil his contractual obligations e. g. opening of a letter of credit, supply of any required domestic or foreign certificates, transfer of an advance payment, checking of drawings and samples etc. we are entitled to postpone our delivery time according to production requirements regardless of our rights resulting from the delay caused by the customer.

5.3 The moment of shipment ex works is of prime importance to the determination whether the delivery time was kept. If it is not our fault that goods cannot be shipped in time the notice that goods are ready for shipment is proof for having respected the delivery time.

5.4 If unforeseen events, e. g. war, act of God, natural phenomenon, accident, production hold-up and delay of supply of essential raw material hinder us or our suppliers to fulfil contractual obligations, the delivery time becomes extended for the period of obstruction plus a reasonable time to get going again. We can withdraw from the contract if delivery becomes impossible or unreasonable. The same right applies to the customer if acceptance of goods becomes unreasonable because of the delay. Strikes and lockouts are obstructions we cannot be held responsible for.

Delivery time is extended for a period during which the customer is causing a delay. If we cause the delay the customer can withdraw from the contract after having granted us a reasonable extension period by written notice. Same applies to us if shipment of goods becomes impossible because of legitimate reason.

We commit ourselves to informing the customer immediately about the occurrence of an unforeseen event.

5.5 The right of withdrawal from the contract to which the customer and ourselves are entitled according to section 5.4 only applies to the unfulfilled part of the contract. If the customer however cannot use the partial shipments already received he is entitled to withdraw from the entire contract.

5.6 Any other rights and in particular claims for damages can be exercised by the customer only if we are guilty of negligence or having acted with intent.

6. FAULTY MATERIAL AND WARRANTY

6.1 In case of an immediate and justified claim of faults we replace or repair the goods (within Germany only!) thus excluding customer's right to any further claim. If the goods are not repaired or replaced within a reasonable time or their repair or replacement has failed again the customer is entitled to a reduction of the goods' value or to demand withdrawal from contract. We can refuse the elimination of defects as long as the customer has not paid the unclaimed part of the shipment. Any further claims by the customer in particular those for damages and warranty which do not relate to the delivered item itself are excluded.

We can only be held responsible for material lacking warranted quality if such warranty specially serves the purpose to protect the customer against the damages occurred.

6.2 The customer must offer us the opportunity by inspection to become convinced that there is a defect by placing at our disposal the faulty material or samples of it.

6.3 If an inspection of goods was carried out claims regarding defects which could have been detected during inspection are excluded.

6.4 Warranty is excluded in case of damages resulting from natural wear, poor or careless handling, excessive use, unsuitable operating material, any natural influence or non-observance of our technical guidelines, assembly instruction and application instructions.

6.5 Warranty claims lapse within 3 months after detection of a defect, latest however within 12 months after receipt of goods.

7. RESERVATION OF TITLE

7.1 All goods delivered shall remain our property (reserved goods) until all our claims have been met in full, in particular any claim in respect of a current debit balance in our favour to which we are entitled within the framework of the existing business relationship. This shall also apply to all future or qualified claims, e. g. claims arising from reverse bills.

7.2 Any processing or finishing of the reserved goods shall be deemed to have been conducted on our behalf as manufacturers within the understanding of § 950 BGB (German Civil Code) and without subjecting us to any obligation. The chattel so processed or finished shall be deemed to constitute reserved goods within the understanding of subsection 7.1.

7.3 In case in which reserved goods are processed, connected or otherwise incorporated by the customer with goods from different owners, we shall be entitled to co-ownership of the new chattel in the same proportion as that of the invoice value of said reserved goods to that of the other merchandise processed.

In cases in which our property is deemed extinguished as a result of such connection, incorporation or processing the customer agrees to assign in advance his proprietary or expectant rights to the new part or object the total of which shall be in the same proportion as that of the invoice value of the reserved goods to the invoice value of the other materials used. The customer also agrees to hold such claims on our behalf free of charge. Our rights to co-ownership shall constitute reserved goods within the understanding of sub-section 7.1.

7.4 The customer shall only be entitled to resell or otherwise dispose of the reserved goods in the ordinary course of business exercised under his standard business terms and only if he is not in default of any payment. This authorization is also subject to the provision that he agrees to a similar reservation of title with his customer, and that any claims arising from said resale shall pass to ourselves in accordance with sub-section 7.5 and 7.8. The use of reserved goods to fulfil a contract for materials and services shall also constitute such a resale.

7.5 The customer assigns in advance any claim accruing to him from the resale of the reserved goods. These claims serve as security to the same extent as do the reserved goods under sub-section 7.1.

7.6 If the reserved goods are sold by the customer together with other merchandise, the claim assigned to us shall be in proportion of the invoice value of the reserved goods to the invoice value of the other merchandise. In the case of goods resold in which we have the right of co-ownership as specified under sub-section 7.3 the claim corresponding to the share of co-ownership must be assigned to us.

7.7 The customer shall retain the authority to collect such assigned claims accruing from the resale of reserved goods until being revoked by us. Upon request he shall immediately inform his customers of the assignment of such claims – if not already done by us – and provide us with all documents and information necessary for their collection.

7.8 The customer shall under no circumstance be authorized to dispose of claims by assignment. This shall also apply to factoring, to which the customer is not even entitled to factoring under the terms of our collection authority.

7.9 The customer must inform us immediately of any attachment or other prejudice in favour of a third party.

7.10 Should the value of securities existing in our favour exceed the total of claims by more than 20% we shall at the request of the customer release such securities at our discretion.

7.11 If a customer is in breach of contract, e. g. default of payment, we are entitled to take back the reserved goods or to demand the assignment of our customer's claim against a third party. The taking back or seizure of reserved goods by us does not represent a withdrawal from contract if not laid down otherwise by the Hire Purchase Law.

8. GENERAL LIMITATION OF LIABILITY

If no separate agreement has been reached to the contrary in above stipulated General Conditions of Business we are liable for indemnity arising from the infringement of contractual or non-contractual obligations only in the event of wilful intent or severe negligence.

We can only be held responsible for wilful intent or severe negligence of our non-executive personnel if the infringement concerns an essential contractual obligation.

According to the Product Liability Law above provision shall not apply to claims arising from personal injury or damage to privately used objects. Goods must be used in compliance with the current safety regulations as well as standards and our operating and mounting instructions. We cannot be held responsible for damages arising from an infringement of these provisions.

9. LAW APPLICABLE

The law of the Federal Republic of Germany shall apply to the above stipulated General Conditions of Business excluding the uniform laws on international purchase and conclusion of contracts of movable commodities.

10. PARTIAL INOPERATIVENESS

If any terms of the contract become inoperative all others remain in effect. An inoperative term can be replaced by any arrangement of which the aim and object come legally close to the invalid term in view of the economical effectiveness.

11. PLACE OF PERFORMANCE AND JURISDICTION

The place of performance and exclusive jurisdiction for all sales including those on the basis carriage paid, FOB, etc. shall be Memmingen/Bavaria if both parties are fully qualified businessmen (§ 29 and 38, ZPO). We are however also entitled to take proceedings against the customer at his place of jurisdiction.

02/2002

- Fax inquiry
- Fax order form

PFEIFER
SEIL- UND HEBETECHNIK
GMBH

DR.-KARL-LENZ-STRASSE 66
 D-87700 MEMMINGEN
 TELEFON +49 (0)8331-937-393
 TELEFAX +49 (0)8331-937-350
 E-MAIL zugglieder@pfeifer.de
 INTERNET www.pfeifer.de

PFEIFER-Tension rod system

Customers address:

Building project:

Company:

Street:

Zip code/City:

Telephone no.:

Fax no.:

Contact:

comments:

Delivery address:

Company:

Street:

Zip code/City:

Telephone no.:

Fax no.:

Contact:

comments:

Diameter (mm)	10 und 12	16 bis 100
Max rod length (mm)	6.000	15.000

Material fork connector: EN-GJS-400-18-LT (GGG40.3)

Material tension rod: S460N

Material intersection plate: S355J2G3

All components are hot dip galvanised according to DIN EN ISO 1461 and DIN EN 22063.

The tension rods are available in untreated, bare on request.

Pos.	comment e.g. L1	surface galvanised yes / no	diameter mm	Systemlength mm	Number
1					
2					
3					
4					
5					
6					
7					
8					
9					
10					
11					
12					

Delivery time:

In according with General conditions of business PFEIFER Seil- und Hebeteknik GmbH.

Fax: +49(0) 8331 / 937-350

PFEIFER



**PFEIFER
SEIL- UND HEBETECHNIK
GMBH**

DR.-KARL-LENZ-STRASSE 66
D-87700 MEMMINGEN
TELEFON +49 (0)8331-937-393
TELEFAX +49 (0)8331-937-350
E-MAIL zugglieder@pfeifer.de
INTERNET www.pfeifer.de